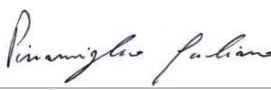

	Test report n.	623-QL18-R01 ver.0
	Applicant/ Antragsteller	Fondmetal S.p.A. Via Bergamo, 4 24050 Palosco (BG) Italy
	EUT/Type	PKW-Rad - Type FMI02_9520

GUTACHTEN über die Dauerfestigkeit von Rädern
Strength Certificate for Wheels

Nr. 623-QL18-R01 ver.0

Adressen Addresses		
Antragsteller Applicant	Fondmetal S.p.A. - Via Bergamo, 4 - 24050 Palosco (BG) Italy	
Hersteller Manufacturer	siehe Antragsteller / same as Applicant	
Prüflabor Test laboratory	Qualilab s.r.l. Via Trento, 87 25020 – Capriano del Colle (BS)	
Daten und Berechtigungen Dates and authorization		
Datum Bericht und Test Report and test date	Siehe Punkt VI / See point VI	
Unterschriften Authorization	Giuliano Pizzamiglio Testing Engineer	 
	Ing. Carsten Seyring Reviewer	
Prüfgegenstand (Herstellerangaben) Equipment under test (declared by the applicant)		
Prüfgegenstand Description equipment under test	PKW-Rad /Wheel for Passenger Cars	
Typ Type	FMI02_9520	
Modell Model	-	
Radgröße Wheel dimension	9,5Jx20 EH2+	
Anzuwendende Normen Applicable norms		
	<p>Die Dauerfestigkeit, der hier beschriebenen Räder, wurde gemäss der "Richtlinien für die Prüfung von Sonderrädern für Kfz und ihren Anh. BMV/StV 13/36.25.07-20.01, VkbI S 1377" vom 25.11.1998 und ECE-R 124 Änd. 00 Erg. 01 geprüft.</p> <p>The strength resistance of the wheels described in this report were tested in accordance with the "guidelines for the testing and inspection of special wheels for motor vehicles and their trailers BMV/StV 13/36.25.07-20.01, VkbI S 1377" from 25th of November 1998 and ECE-R 124 Supp. 00 amend. 01</p>	

The test results and observations indicated in this test report refer exclusively to the samples tested. It is not permitted to transfer the results to other systems or configurations. The publication or duplication of this test report with enclosures, or Part of this test report or enclosures, without a written consent of the test laboratory is not permitted. The test laboratory not assumes any liability to any party for any loss, expense or damage occasioned by the use of this report. Any use of the laboratories name or one of its marks for the sale or advertisement of the tested material, product or service must first be approved in writing by the test laboratory. In case of a multilingual test report, the English version is the only official version.

§ 22 51997

	Test report n.	623-QL18-R01 ver.0
	Applicant/ Antragsteller	Fondmetal S.p.A. Via Bergamo, 4 24050 Palosco (BG) Italy
	EUT/Type	PKW-Rad - Type FMI02_9520

0. Zentrierart / Centering type

Mittenzentrierung

Centering on Hub Flange

I. Übersicht / Overview

Ausführung/ Version	Kennzeichnung Rad/Zentrierung Wheel identification/ centering rings	Lochzahl/ Lochkreis/ Mittenloch-Ø [mm] Number of holes/ PCD/ centre hole Ø	ET [mm] offset	Radlast [kg] Wheel load	Abroll- umfang [mm] Rolling circum- ference	Gültig ab Herstell- datum Valid from production date
43 5112R	FMI02_9520 43 5112R / ohne Ring	5/112/66,5	43	750	2395	04/2018
44 5120C	FMI02_9520 44 5120C / ohne Ring	5/120/72,5	44	750	2395	04/2018

I.1. Beschreibung der Räder / Description of wheels

Handelsmarke Trade mark	FONDMETAL
Art der Räder Type of wheels	Einteiliges Leichtmetall Rad Aluminum One piece wheels
Korrosionsschutz Corrosion protection	Mehrschicht Einbrennlackierung Multilayer Coating , Baked Paint
Masse des Rades Weight of wheel	16,58 kg * ohne Lackierung / Unpainted * Weigth referes to wheel controlled under I.3

I.2. Radanschluss und Befestigungselemente / Wheel attachment and fastening elements

Siehe Punkt I. Übersicht und Anhaenge

See point I. overview and enclosures

I.3. Kennzeichnung der Räder / Wheel identification

An den Rädern wird folgende Kennzeichnung an der Außen- bzw. Innenseite eingegossen bzw. eingeprägt, siehe Beispiel Radausführung 44 5120C

The following identification will be casted or impressed on the inner and/or outer side of the wheel , see sample wheel version 44 5120C

	Außenseite / Outer side	Innenseite / Inner side
Herstellerzeichen / Manufacturer sign	-	FONDMETAL
Radtyp / Wheel type	-	FMI02_9520
Radausführung / Version	-	s.p. I Übersicht / <i>overview</i>
Radgröße / Wheel dimension	-	9,5Jx20 EH2+
Einpreßtiefe / Offset	-	s.p. I Übersicht / <i>overview</i>
Herstellungsdatum / Date of manufacturing	-	Monat und Jahr
Herkunftsmerkmal / Origin	-	Made in Italy
Gießerei-kennzeichnung / Casting identification	-	-
KBA Nummer / KBA number	-	-
ECE Nummer / ECE number	-	-

Zusätzlich können auf der Radinnenseite bzw.-außenseite verschiedene Kontrollzeichen angebracht sein.

Additionally other control labels could be affixed on the outer- or inner side of the wheel.

	Test report n.	623-QL18-R01 ver.0
	Applicant/ Antragsteller	Fondmetal S.p.A. Via Bergamo, 4 24050 Palosco (BG) Italy
	EUT/Type	PKW-Rad - Type FMI02_9520

I.4. Verwendungsbereich / Application field

Die Räder sind fuer Personenkraftwagen vorgesehen.

The wheels are designated to be mounted on passenger cars.

II. Radprüfung / Wheel testing

Die Dauerfestigkeit, der hier beschriebenen Räder , wurde gemäss der “Richtlinien für die Prüfung von Sonderrädern für Kfz und ihren Anh. BMV/StV 13/36.25.07-20.01, VkB1 S 1377“ vom 25.11.1998 und ECE-R 124 Änd. 00 Erg. 01 geprüft.

The strength resistance of the wheels described in this report were tested in accordance with the “guidelines for the testing and inspection of special wheels for motor vehicles and their trailers BMV/StV 13/36.25.07-20.01, VkB1 S 1377” from 25th of November 1998 and ECE-R 124 Supp. 00 amend. 01

II.1. Felge / Rim

Die Maße und Tolleranzen der Felgenkontour entsprechen der E.T.R.T.O. Norm.

Dimensions and tollerances of the rim-contour are in accordance with the E.T.R.T.O.

II.2. Werkstoffe der Räder / Materials of wheels

Zusammensetzung, Festigkeitswerte und Korrosionsverhalten des Werkstoffes sind in der Beschreibung des Herstellers aufgefuehrt; diese Angaben wurden durch uns nicht ueberprueft.

Composition, strength values and corrosion behaviour of the materials are listed in the technical description of the manufacturer, these data are not verified by us.

II.3. Festigkeitsprüfung / Strength test

II.3.1. Dauerfestigkeitsprüfung / Endurance strength test

Prüfinstrument / Measurement instrument:

LEONARDO FR12 QL internal n° QL-IN-069 and Inmess RBT-8K internal n° QL-IN-089

Ausführung/ Version	Lochzahl/Loch- kreis [mm]/ Number of holes/ PCD	ET [mm] Offset	Radlast [kg] Wheel load	Abroll- umfang [mm] Rolling circumference	Prüfmoment Mb max bei 100% [Nm] Bending moment	Anzahl Kurz- zeittest Short time test qty	Anzahl Lang- zeittest Long time test qty
43 5112R	5/112	43	750	2395	5681	1	1
44 5120C	5/120	44	750	2395	5696	1	1

Die Prüfung wurde mit positivem Ergebnis abgeschlossen.

The test was performed with positive result.

II.3.2. Abrollprüfung / Rim rolling test

Prüfinstrument / Measurement instrument:

Rim rolling machine GOAL QL internal n° QL-IN-068

Ausführung/ Version	Lochzahl/Loch -kreis-[mm]/ Number of holes/ PCD	ET [mm] Offset	Radlast [kg] Wheel load	Prüf- last [daN] Test Load	Reifengröße Tire dimension	Reifenfüll- druck [bar] Tire pressure	Prüf- distanz [km] Test distance	Anzahl Abroll- test Rolling- Test qty
43 5112R	5/112	43	750	1840	305/50 R20	4,5	2000	1
44 5120C	5/120	44	750	1840	305/50 R20	4,5	2000	1

Die Prüfung wurde mit positivem Ergebnis abgeschlossen. Alle anderen Versionen sind abgeleitet.

The test was performed with positive result. All other versions are derived.

	Test report n.	623-QL18-R01 ver.0
	Applicant/ Antragsteller	Fondmetal S.p.A. Via Bergamo, 4 24050 Palosco (BG) Italy
	EUT/Type	PKW-Rad - Type FMI02_9520

II.3.3. Impact Prüfung / Impact test

Prüfinstrument / Measurement instrument:
Impact tester INMESS QL internal n° QL-IN-153

Ausführung/ Version	Lochzahl/Lochkreis [mm]/ Number of holes/ PCD	ET [mm] Offset	Radlast [kg] Wheel load	Fallmasse [kg] Impact weight	Reifengröße Tire dimension	Reifenfüll- druck [bar] Tire pressure	Anzahl Impact- test Impact-Test qty
43 5112R	5/112	43	750	630	245/35 R20	2,0	2
44 5120C	5/120	44	750	630	245/35 R20	2,0	2

Die Prüfung wurde mit positivem Ergebnis abgeschlossen.
The test was performed with positive result.

III. Prüfergebnis / Test result

Aufgrund der durchgeführten Prüfungen bestehen keine technischen Bedenken o.g. Räder an den in Verwendungsbereichsgutachten genannten Fahrzeugen und den dort aufgeführten Bedingungen zu verwenden.
Based on the performed tests there are no technical objections to apply the wheels described above to the vehicles listed in the application certificate under fulfillment of the mounting conditions.

IV. Hinweis / Note

-

V. Anlagen /Enclosures

Beschreibung / Technical description :	Date 22/05/2018
Radzeichnung / Drawing n° : FMI02_9520435	rev.0 date 18/04/2018
Radzeichnung / Drawing n° : FMI02_9520445	rev.0 date 18/04/2018

VI. Datum Bericht und Test /Report and test date

Ver. 0: 25/05/2018 - Test Date: From 10/05/2018 to 21/05/2018

WHEEL DESCRIPTION

Please find details of wheels supplied to TUV for testing listed below.

Certification request: Strength Certificate (Dauerfestigkeit) + ABE Document

1. General information

- Wheel Type: FMI02_9520
- Wheel Size: 9.5 J x 20" EH2+
- Tyre type: Tubeless
- Snow chain: See TUV indications
- Face Parallelity and Roundness of Rim: 0.30 mm
- Rim Base: According To Std. E.T.R.T.O.
- Valve Type: Customer Own (STD E.T.R.T.O. 11.3F)
- Balancing Weights: Only Adhesive

2. Applications

- All models homologated

3. Measurement and other

PART NUMBER		ET	PCD	C.B.	Rings	Bolt & Nuts	Application
FMI02_9520	43 5112R	43	5x112	66.5	-	OE BOLT V011	Audi, BMW, Mini, mercedes, Seat, Skoda, VW
FMI02_9520	44 5120C	44	5x120	72.5	-	OE BOLT	BMW

4. Drawings / Accessories

- Wheel drawing numbers: FMI02_9520435 rev.0
FMI02_8520445 rev.0
- Centering: See draw in attachment
- Hubcap: See draw in attachment
- Valve: See draw in attachment
- Wheel Bolt/Nut: See draw in attachment
- Starting Torque the Wheel Nuts: See TUV Indication

5. Construction

- Wheel Standard: E.T.R.T.O.
- Construction: One Piece Wheels
- Design: Fondmetal Wheels

6. Description of the Wheel Manufacturing

- Features: Gravity casting
- Heat treatment: No
- Machining Process: Fully CNC Machined & CNC drilling
- Varnishing: 3 layer, powder coat, colour paint, lacquer

7. Material

- Material: Aluminium alloy G-Al Si10 Cu
- Enervations load: Rp02 70 N/mm2
- Tension strength: Rm 140 N/mm2
- Elongation: A 2%
- Density: 2.65 kg/dm3
- Hardness: Min. 50 HB
- Chemical Analysis:

Silicio Si%	Rame Cu%	Ferro Fe%	Manganese Mn%	Zinco Zn%	Magnesio Mg%	Titanio Ti%
10÷11,5	0,4±,0,8	Max 0,50	0,2±0,5	Max 0,45	Max 0,15	Max. 0,15

Cromo Cr%	Nichel Ni%	Piombo Pb%				
Max. 0,1	Max. 0,1	Max. 0,1				

8. Corrosion Consistency of the Material

- Against influence of the water: Very good
- Against seawater: Very good - Minimum 384 hours Corrosion Protection to UNI ISO 9227

9. Quality Control

- Material Analysis
- 100% X-Ray Analysis
- Dimensional Inspection Throughout manufacture
- Statistical Process Control on Critical Dimensions
- A 100% tubeless
- A 100% visual inspection

10. Production plant

- Casting: Fondmetal Spa, Via Bergamo, Palosco BG
- Machining Process: Fondmetal Spa, Via Bergamo, Palosco BG
- Varnishing / Paint Finish: Fondmetal Spa, Via Bergamo, Palosco BG
- Finish Control: Fondmetal Spa, Via Bergamo, Palosco BG
- Dispatch/Delivery: Fondmetal Spa, Via Bergamo, Palosco BG

2018-05-22

Ufficio tecnico Fondmetal

§ 22 51997

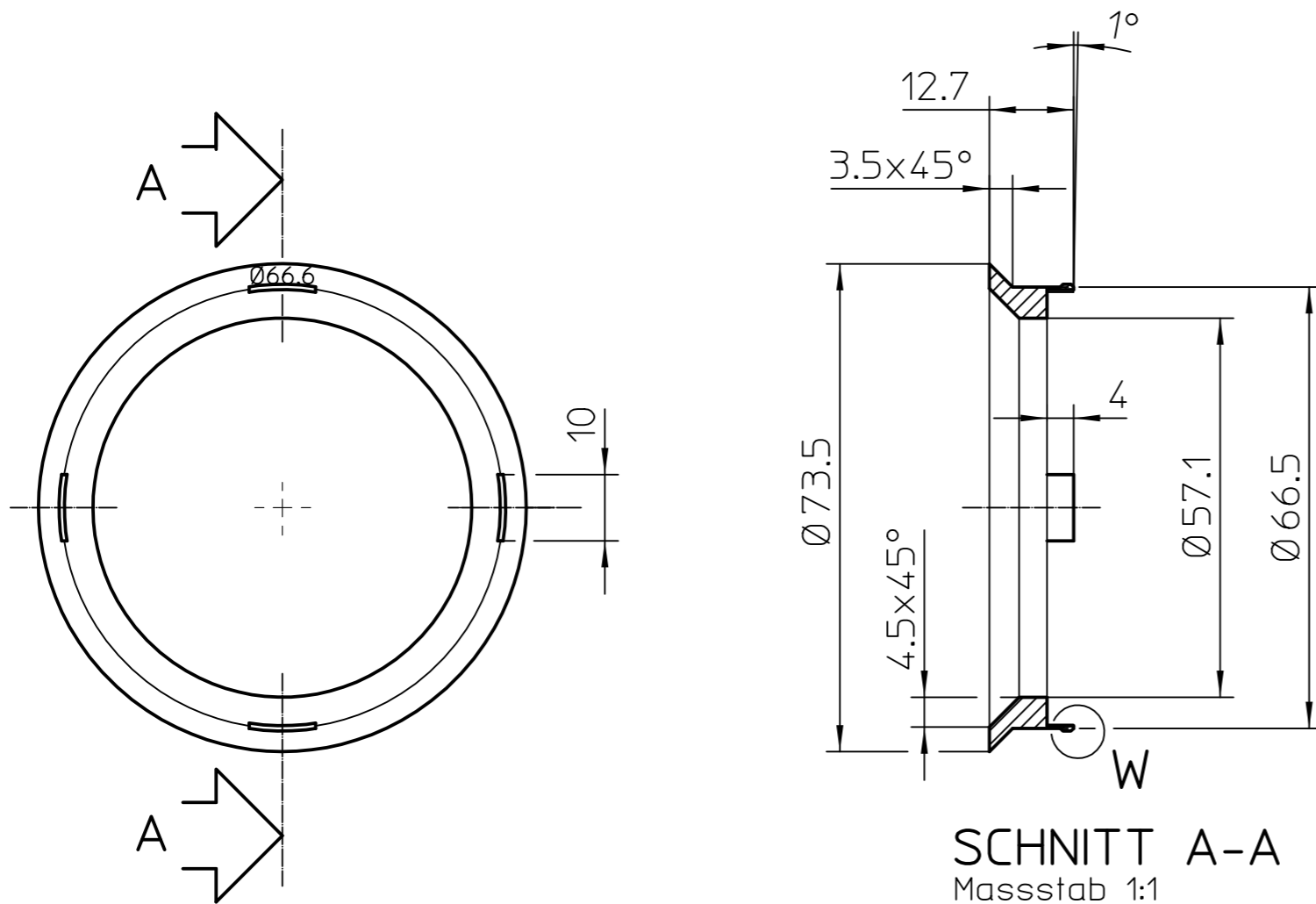

SCHNITT A-A
Massstab 1:1

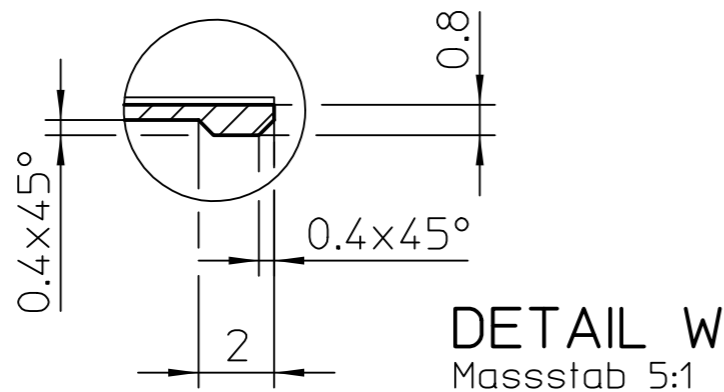
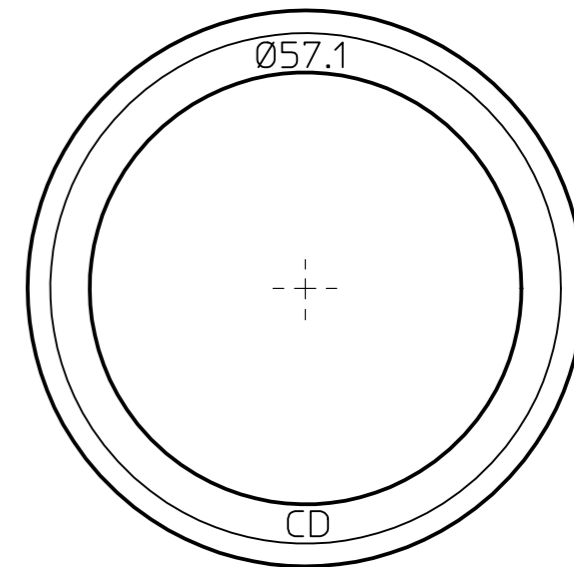

DETAIL W
Massstab 5:1

DENOMINAZIONE: Beschreibung		ANELLINO DI CENTRAGGIO			
 Via BERGAMO 4, PALOSCO (BG) ITALY www.fondmetal.com	CODICE PARTICOLARE Teilenummer	AA 01			
	DISEGNO N° Zeichnung Nr.	1AN_AA01			
	MATERIALE Werkstoff	PA66 FV20			
	FINITURA Lackierung	Plastica ROSSO			
	Riferim. Cod. BIMECC Referenz-code BIMECC	AP666571			
	DISEGNATO DA Gezeichnet von	S. FORESTI			
	CONTROLLATO DA Überprüft von	S. RAINERI			
	DATA Datum	22/04/2015	SCALA Maßstab	1:1 (5:1)	
	REV.	A0			

ALLE EIGENTUMSRECHTE VON FONDOMETAL S.P.A. VORBEHALTEN. DER NACHDRUCK ZUR HERSTELLUNG DER HIER DARGESTELLTEN TEILE SOWIE DIE WEITERGABE AN DRITTE DIESER ZEICHNUNG IST, OHNE SCHRIFTLICHE GENEHMIGUNG SEITENS FONDOMETAL S.P.A., UNTERSAGT. JEDLICHE ZUWIDERHANDLUNG WIRD STRAFRECHTLICH VERFOLGT.

TUTTI I DIRITTI DI PROPRIETA' SONO RISERVATI A FONDOMETAL S.P.A.. SENZA AUTORIZZAZIONE DELLA STESSA SE NE VIETA SIA LA RIPRODUZIONE ANCHE SOLO PARZIALE PER LA COSTRUZIONE DEI PEZZI RAPPRESENTATI, SIA LA COMUNICAZIONE A TERZI DEL PRESENTE DISEGNO. QUALSIASI INOSSERVANZA VIENE PUNITA A NORMA DI LEGGE.

§ 22 51997

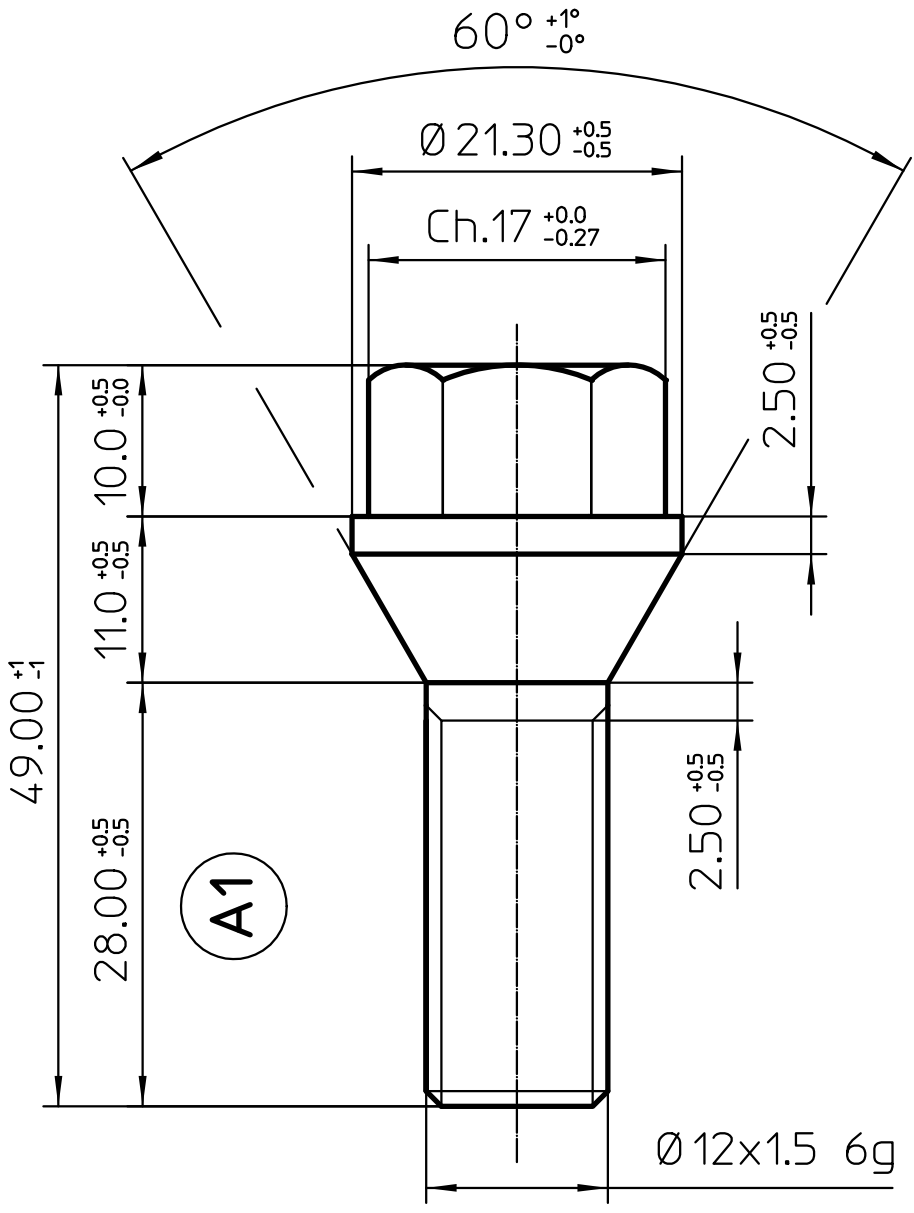

A1



22/05/98

MODIFICATO QUOTA DA 29mm. A 28mm.

A1

DENOMINAZIONE:
Beschreibung

C VITI 12 x 1.5 ch.17

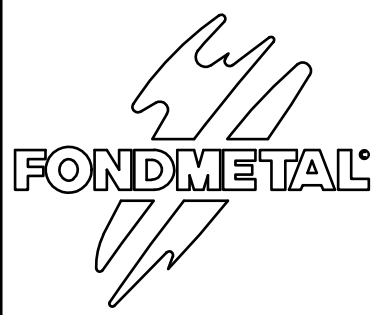

CODICE PARTICOLARE Teilenummer	V010
DISEGNO N° Zeichnung Nr.	/
MATERIALE Werkstoff	10.9
FINITURA Lackierung	/
DISEGNATO DA gezeichnet von	S. FORESTI
CONTROLLATO DA Überprüft von	S. RAINERI
DATA Datum	16/05/95
SCALA Maßstab	2:1
REV.	A1

TIPO DI VEICOLO
FAHRZEUG TYP

Via BERGAMO 4
PALOSCO (BG) ITALY

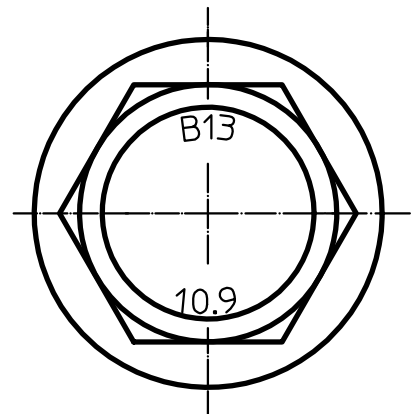
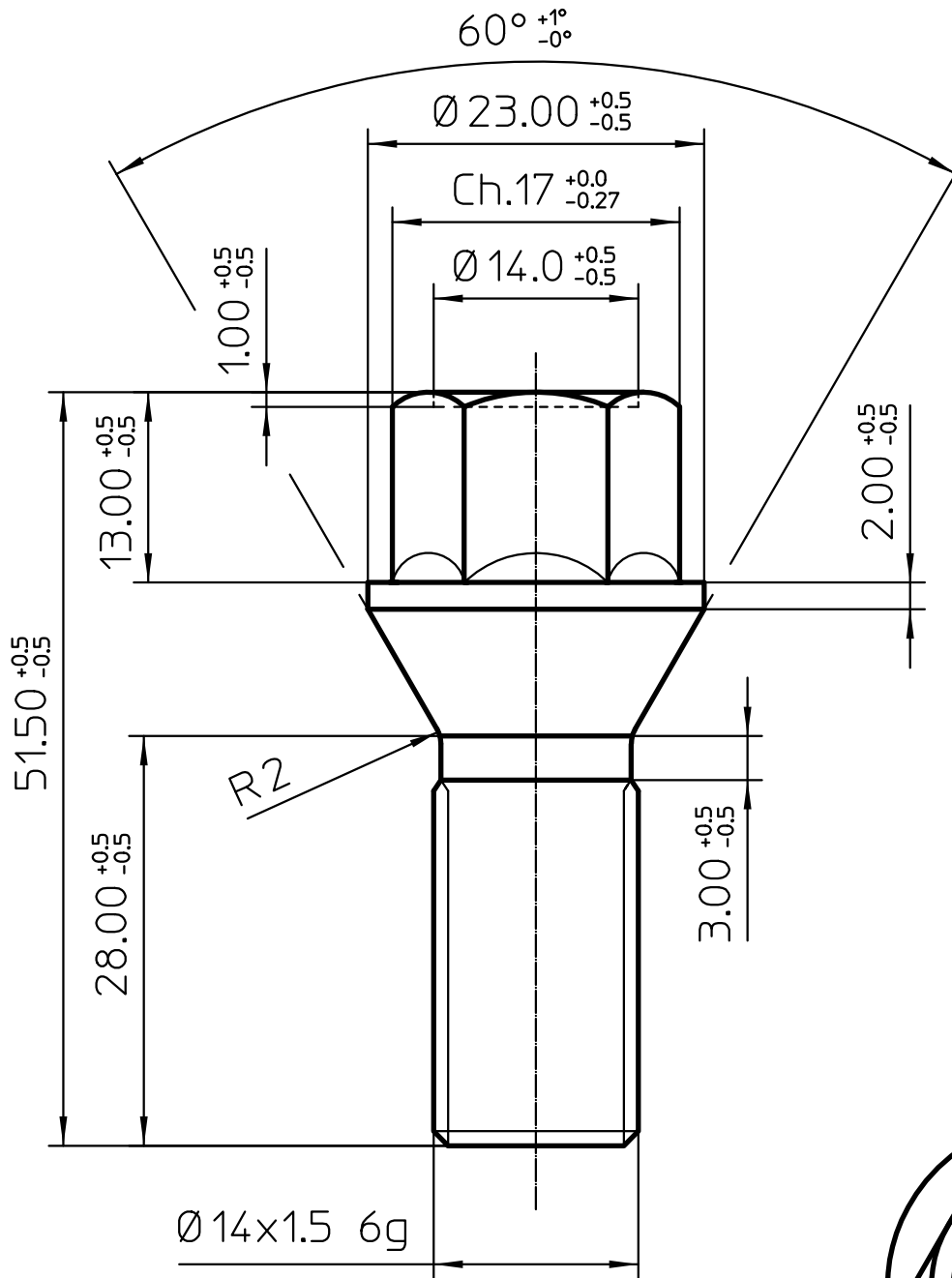

DENOMINAZIONE:
Beschreibung

C VITI 14 x 1.5 ch.17

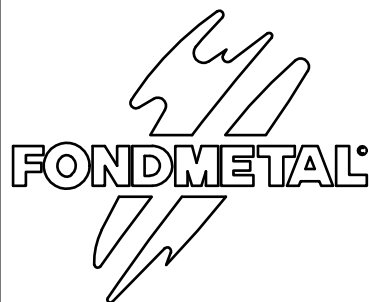

Via BERGAMO 4
PALOSCO (BG) ITALY

CODICE PARTICOLARE
Teilenummer

V011

DISEGNO N°
Zeichnung Nr.

/

TIPO DI VEICOLO
FAHRZEUG TYP

MATERIALE
Werkstoff

10.9

FINITURA
Lackierung

/

DISEGNATO DA
gezeichnet von

S. FORESTI

CONTROLLATO DA
Überprüft von

S. RAINERI

DATA
Datum

18/06/98

SCALA
Maßstab

2:1

REV.

A0

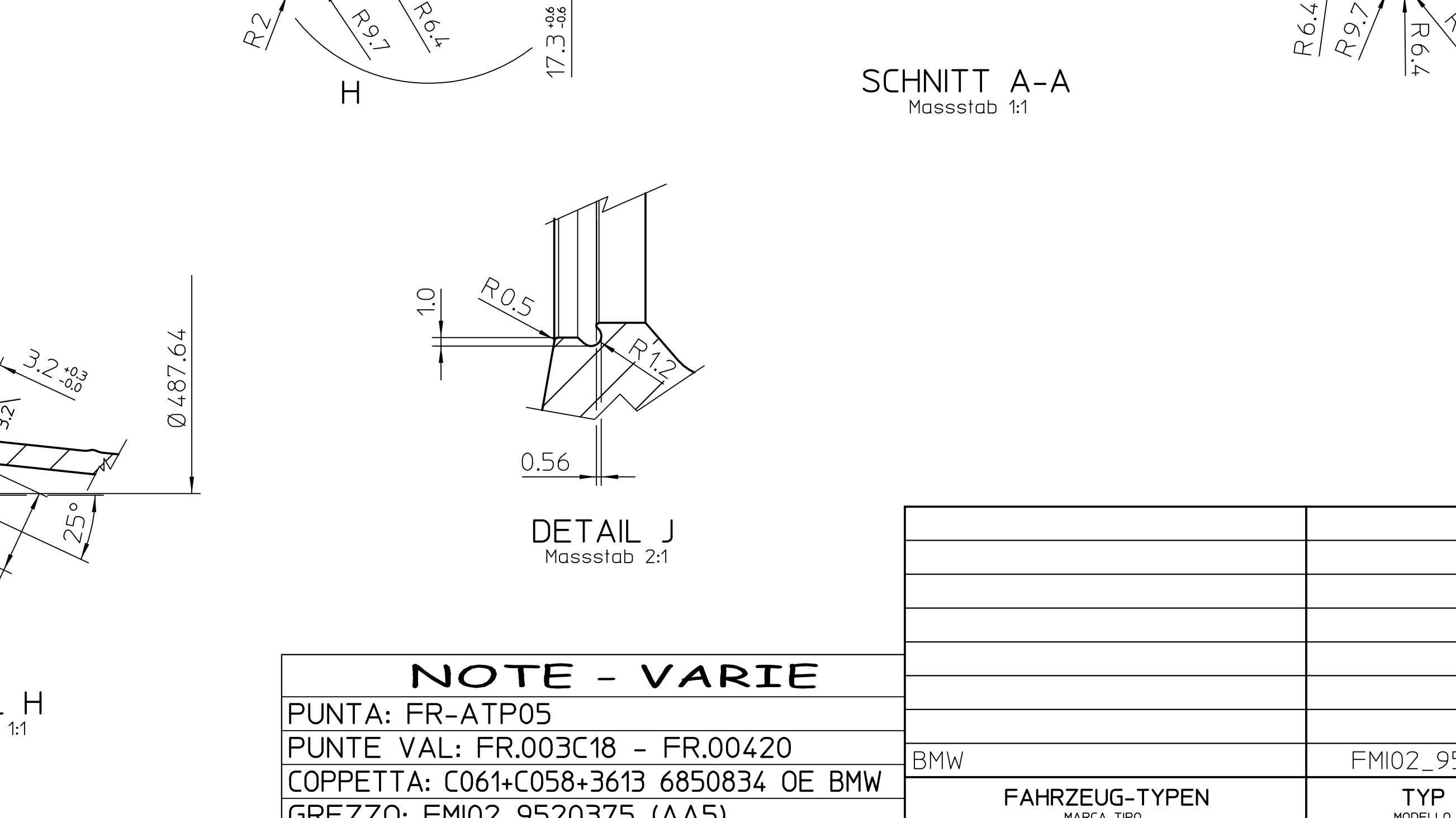
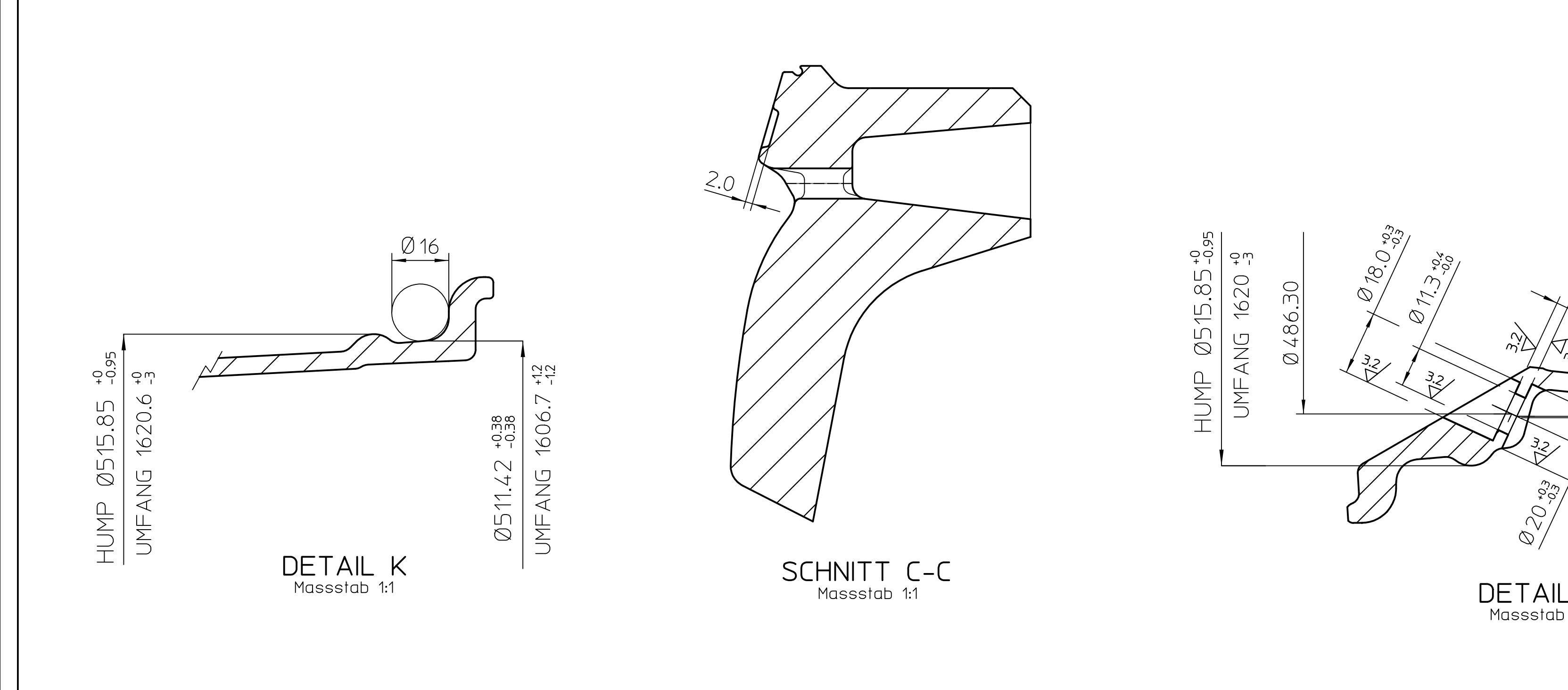
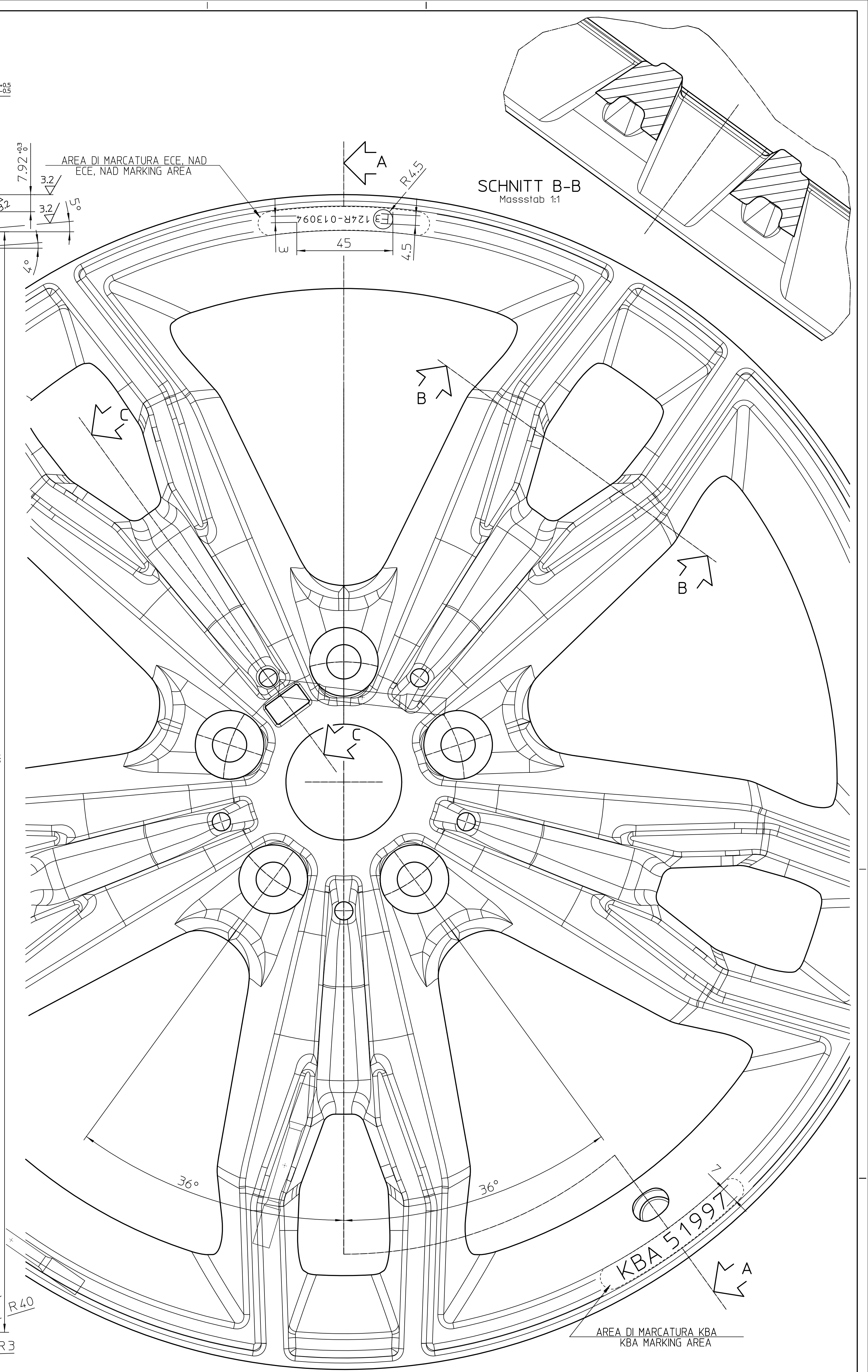
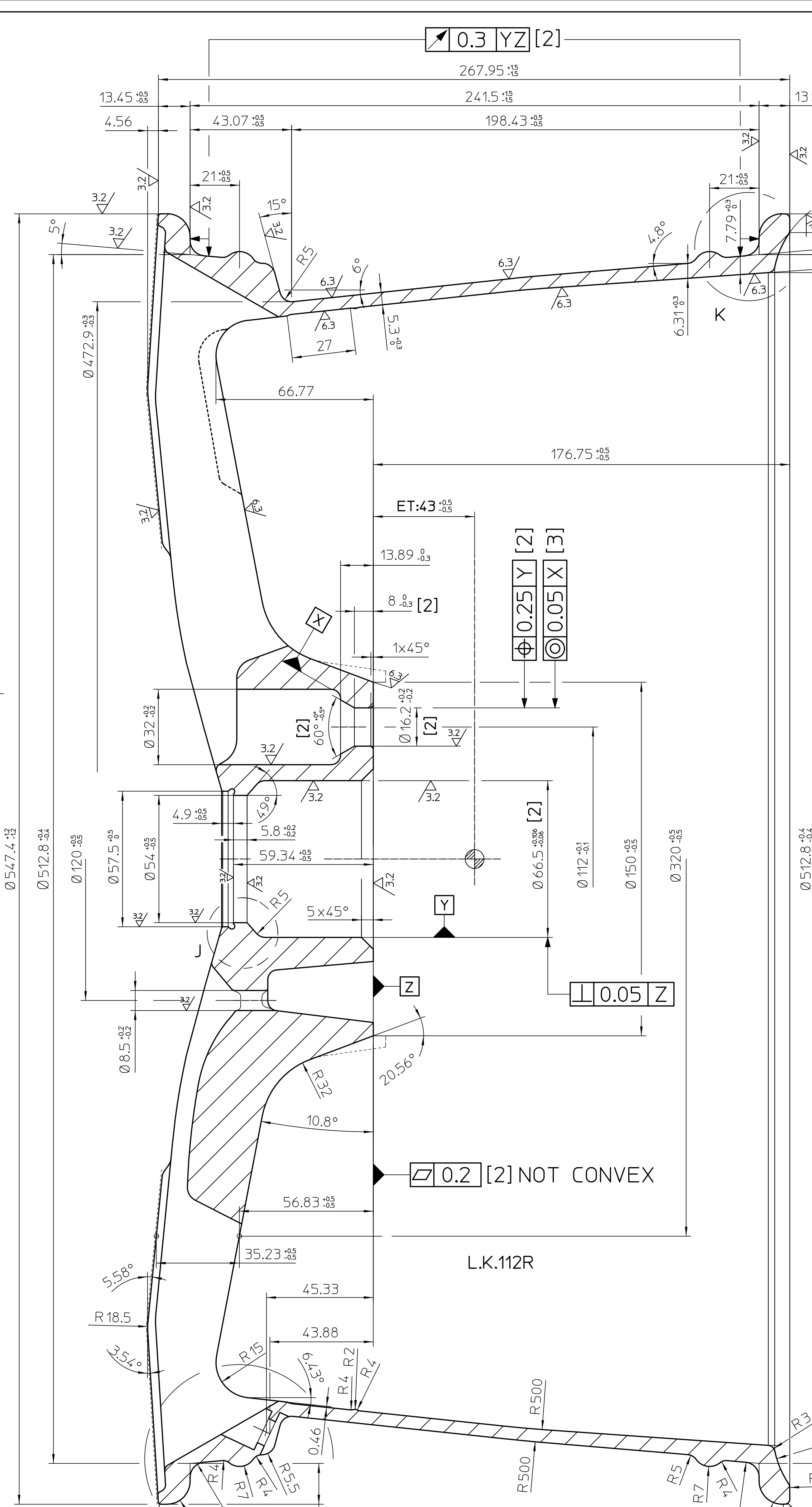
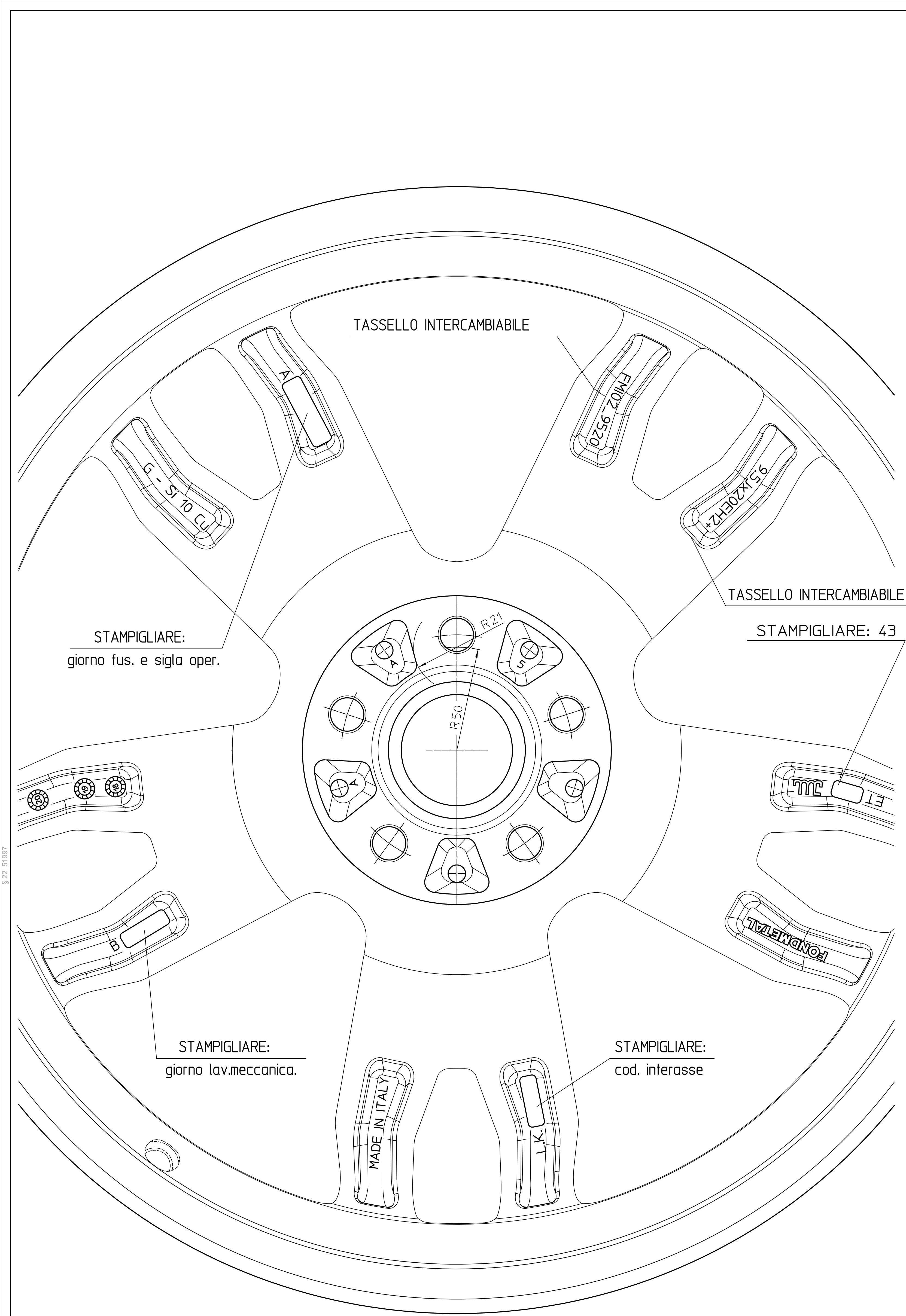

ZONE PROTETTE DALLA VERNICIATURA:
 LACKGESCHÜTZTE OBERFLÄCHE:
 -CENTRATURA (MITTENBOHRUNG)
 -PIANO D'APPoggio (ANLIEGEFLÄCHE)

[2] QUOTA IMPORTANTE (WICHTIGES MASS)
 [3] QUOTA MOLTO IMPORTANTE (SEHR WICHTIGES MASS)

BILANCIATURA DINAMICA MAX Ant.40gr Post.30gr, CON VALVOLA TR413
 DYNAMISCHE UNWUCHT VA MAX. 40gr DYNAMISCHE UNWUCHT HA MAX. 30gr, MIT VENTIL TR413

GREZZE TUTTE LE PARTI SENZA SEGNO DI LAVORAZIONE
 ALLE PUNTE OHNE BEARBEITUNGSKENNZEICHEN SIND UNBEARBEITET

 Via BERGAMO 4 PALOSCO (BG) ITALY www.fondmetal.com		 KBA 51997	TYP: FMI02_9520 MODELLO: 9.5Jx20EH2+ GRÖÖE: 1:1 (2-1) DATUM: 18/04/2018 ZEICHNUNGS-NR.: FMI02_9520435 GEZEICHNET VON: GIRELLI S. ÜBERPRÜFT VON: CORIONI G.
KENNZEICHNUNG: DESCRIZIONE AUDIENSTE: FRONTALE INNENSEITE: POSTERIORE	HERSTELLER: PRODUTTORE TYP: MODELLO GRÖÖE: MISURA ENPREITTEPE: ET HERSTELLUNGS-LAND: FABBRICATO IN HERSTELLUNGS-DATUM: DATA DI FUSIONE	FONDMETAL FMI02_9520 9.5Jx20EH2+ E1:43 MADE IN ITALY DATUM L.K. G. SIO CU	ÜBERPRÜFT VON: CORIONI G. CONTROLLO DA:
WERKSTOFF: MATERIALE BEARBEITUNG: ALLE NICHT VERMÄHTEN RADIIEN 0.5mm 3/2 3/3 UND LÖCHKREIS: +0.1mm UM DEN THEORETISCHEN MITTELPUNKT INTERASSSE: +0.1mm SULLA MEZZASA	NACH ENTFETTUNG LACKIERUNG NACH VORSCHRIFT VERNICIATURA DOPO SGRAZZATURA SECONDO DISPOSIZIONI	NACH ETR 10-NORM DIE IN DER NORM ANGEGEBENEN TOLERANZEN SIND ZU BEACHTEN SPANLÖSUNG: +0.25mm SPANABREIBEND: +0.25mm WINKEL SPANABREIBEND: +0° 30'	5 REV

NOTE - VARIE
 PUNTA: FR-ATP05
 PUNTE VAL: FR.003C18 - FR.00420
 COPPETTA: C061+C058+3613 6850834 OE BMW
 GREZZO: FMI02 9520375 (AA5)

BMW	FMI02_9520	43	112R	66.50	/	/	5
FAHRZEUG-TYPEN MARCA-TIPO	TYP MODELLO	ET	L.K. INTERASSE	M.B. CENTRATURA	KENNZERZEICHNERING ANELLO DI RIDUZIONE	INNEN-DURCHMESSER DIAMETRO INTERNO	REV

